

**SHURE**<sup>®</sup>

LEGENDARY  
PERFORMANCE™

# AUDIO SYSTEMS GUIDE

**MUSIC  
EDUCATORS**

By Gino Sigismondi



A Shure Educational Publication





## Table of Contents

<b>Introduction</b> .....	4
<b>Recording</b> .....	5
The Parts of a Recording System .....	5
Microphones .....	5
Recording Devices .....	10
Mixers .....	11
Hooking it up .....	12
<b>Sound Reinforcement for Music</b> .....	12
A Basic Sound System .....	12
Microphones .....	13
Mixers, Amplifiers and Loudspeakers .....	17
Signal Processors .....	19
Hooking it up .....	22
<b>Sound Reinforcement for Theater</b> .....	23
The Realities of Theater Sound .....	23
Lavalier Microphone Techniques for Theater .....	25
<b>Summary</b> .....	27
<b>Recommended Shure Microphone Models</b> .....	28
<b>Appendix</b> .....	29
<b>About the Author</b> .....	29
<b>Glossary</b> .....	30



# Music Educators

## Audio Systems Guide for MUSIC EDUCATORS

### Introduction

*An often overlooked yet vital part of modern musical performances is the sound reinforcement (PA) system. In a perfect world, a trained professional would always be available to purchase, setup, and operate the sound system. In reality, the funds are not always available for such a luxury. The responsibility then falls to the next most likely person available to run the sound system, the music director. After all, you just need a few microphones and a couple of loudspeakers, and it's time to go on tour! And we want it recorded as well!*

*Unfortunately, sound system setup is not quite that simple. It doesn't, however, need to be overly complicated. While the extreme quantity of choices available at your local music shop may seem daunting (Cardioid? Dynamic? Low Impedance! Help!), with a few basic guidelines, you can learn what you need, how to connect it, and even how to make it sound good.*

*This guide will help you choose equipment for a variety of typical applications.*

*Recording will be discussed first, due to the smaller number of required components, and reduced complexity. Feedback and room acoustics play a small (or even non-existent) role in basic recording. Additionally, many of the microphone, and possibly mixer, choices made for recording are equally applicable in live sound reinforcement. Remember, there are few rules in audio – if it sounds good to you, it is good. For every application, there will be a good, better, and best option. A little knowledge and some common sense will allow you to choose a good system with a reasonable budget and a minimum of frustration.*

*For those interested in the more technical aspects of audio equipment, Shure publishes several booklets on a variety of audio topics, including specific microphone techniques and wireless microphone operation.*

# Introduction



## RECORDING

### *What do I need?*

#### The parts of a recording system

To make a decent recording there are two or three components to consider:

1. The first, and most important, is the microphone. Choosing the right microphone ensures accurate pickup of the desired sounds.

2. Next, consider the recording device. Recording equipment comes in many shapes and sizes, from simple cassette tape recorders to advanced digital multitrack machines.

3. Lastly, depending on the capabilities of the recording device, you may need a mixer. A mixer's purpose is two-fold; they are used to combine (or "mix") multiple microphones together, and to properly interface microphones to the recording device. Most consumer-quality cassette tape recorders, for example, do not allow a microphone to be directly connected to the record inputs. A microphone has an extremely low output level that would result in little or no signal actually making it to tape. A mixer provides **gain**, which raises the signal level from the microphone to a level that is acceptable to recorders that don't have microphone inputs.

### Microphones

The most important questions to ask when choosing microphones are:

- a) what are you recording? and
- b) what are you using to record?

First, a little about microphones. Microphones are basically simple devices designed to do one thing: convert sound waves in the air to their electrical equivalent. One of the first questions you may encounter is, "Do you want a **dynamic** or **condenser** microphone?" These are the two most popular types of microphones in the world.

- Dynamic microphones are typically inexpensive and rugged, with fairly low **sensitivity**. In layman's terms, this means they are good for handheld or "close-miked" applications. Dynamics are commonly used for solo vocalists and on drum kits.

- Condenser microphones, on the other hand, are typically (but not always) much more sensitive than dynamics. Make a good quality condenser microphone your first choice for miking ensembles, or other applications where the microphone will be placed at a distance (> 2 ft.) from the sound source. Condensers are typically used for recording orchestras, choirs, and in other applications where you wish to capture the sound of the ensemble, versus individual sounds.

Audio Systems Guide for  
**MUSIC EDUCATORS**

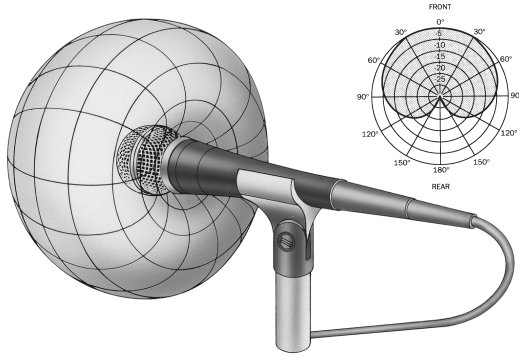

Cardioid (Unidirectional) Microphone

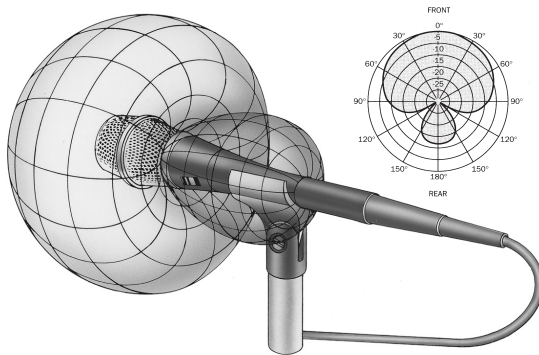

Supercardioid Microphone

Another characteristic of microphones that will determine the best choice for your application is their directionality, or “polar pattern.”

An omnidirectional microphone has equal sensitivity at any angle. Sounds are reproduced equally whether arriving at 0 degrees (on axis) or at 180 degrees (the rear of the mic). The important thing to remember is that omnidirectional microphones will pick up ambient or room sound as well as the sound you intend to amplify or record.

A unidirectional microphone is most sensitive to sound arriving on axis and less sensitive to sound as it moves off axis. Using unidirectional microphones can allow higher gain levels from the sound system before feedback becomes a problem. There are two primary types of unidirectional microphones. Cardioid microphones exhibit an upside down heart-shaped pattern with a 130-degree pickup angle in front. Sound is greatly attenuated at 180 degrees. Supercardioid microphones exhibit a narrower pickup angle of around 115 degrees in front and therefore are even less sensitive to ambient sounds.

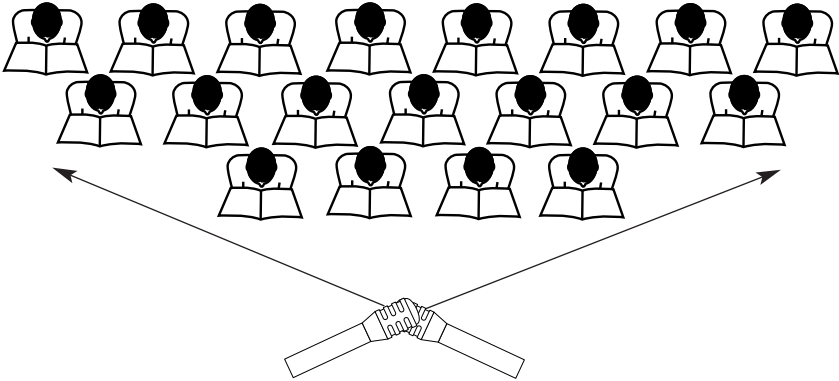

Figure 1: Choir microphone positions - stereo top view

### **Large ensembles (band, orchestra, choir)**

Use a **stereo microphone** setup to most accurately capture the sound of a large ensemble. Stereo recording is not as complicated as it sounds. For simplicity sake, we'll use the most basic type of stereo microphone techniques, the X-Y pattern. Use two microphones of the same model with the two mic capsules placed as close as possible, and facing each other at an angle ranging from 90–135 degrees, depending on the size of the sound source. (see figure 1). For a wider coverage area, the larger angles should be used. The X-Y pattern results in good stereo separation and excellent mono compatibility.

A second, somewhat simpler way to record in stereo uses what is known as a "single-point" stereo microphone. These types typically have a single microphone housing that contains two microphone elements, electrically combined to produce a stereo output. The advantage to this type of microphone is simplicity; put the microphone on a stand and point it at what you want to record.

When recording a large ensemble, you may choose to use more than two microphones to adequately cover each section. A technique known as "area" coverage uses multiple microphones to cover small sections of the ensemble. Using a choir as an example, use one microphone for each 6-9 foot wide section, and aim the microphone capsule towards the last row. Microphones should be placed 2-3 feet in front of the first row of the choir (see figure 2). The same technique can be applied to concert band or orchestra, by using one microphone per section.

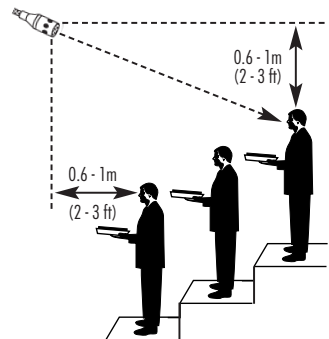

Figure 2: Area miking - side view

## Audio Systems Guide for MUSIC EDUCATORS

### Recommended Equipment

- 2 **cardioid**-pattern condenser microphones
- Microphone stand(s)
- Stereo microphone adapter or “T-Bar”
- Microphone cables with XLR connectors
- Stereo microphone mixer with at least 2 microphone inputs
- Recording device (see next section)
- Cables to connect mixer to recording device

### Small ensembles (jazz combos, string quartet, vocal jazz groups)

The stereo techniques described above can also be successfully applied to smaller ensembles, but to achieve a more “pop” sound, use multiple close microphones, generally one per instrument. On the following page are some simple techniques for getting good sounds for a variety of instruments or vocals.

### Recommended Equipment\*

- Vocal microphone
- Guitar amplifier microphone
- Drum microphones
- Piano microphone
- Woodwind microphones
- Brass microphones
- Microphone stands
- Microphone cables with XLR connectors
- Microphone mixer with enough inputs to handle the desired number of microphones
- Recording device (see next section)
- Cables to connect mixer to recording device

\*Studio recording can use a combination of omnidirectional, cardioid, and supercardioid microphones.

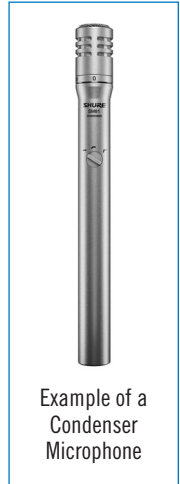

Example of a  
Condenser  
Microphone



Example of a  
Dynamic  
Microphone

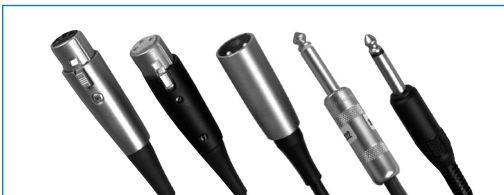

Connectors commonly used for audio from left to right:  
3-Pin XLR female,  
3-Pin XLR female – black,  
3-Pin XLR male,  
1/4" mono plug,  
1/4" mono plug – black



**Vocals** – Try using a handheld style (although mounted on a stand to reduce handling noise) cardioid or supercardioid dynamic microphone. Place the microphone roughly 3-4 inches away, and pointed somewhere between the nose and mouth. If possible, try to isolate the vocalist from any unwanted sounds – in another room would be ideal (see figure 3).

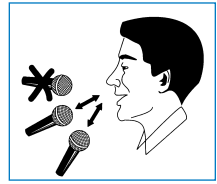

Figure 3

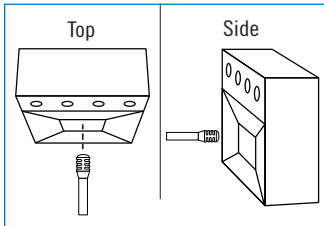

Figure 4

**Electric Guitar Amplifier** – Use a dynamic microphone roughly 1-4 inches from the loudspeaker, pointed toward the center of the speaker cone (see figure 4).

**Drums** (see figure 5) – While seemingly complex, you can achieve a relatively decent drum sound with only four microphones:

– **Kick Drum** –

Place a cardioid dynamic inside the drum, approximately 1-6 inches from the beater head.

– **Snare Drum** –

Use a cardioid dynamic to mike the top head, placed at a 45 degree angle.

– **Toms and cymbals** – Use a pair of condenser microphones suspended over the drum kit, either spaced apart or using one of the stereo microphone techniques described earlier.

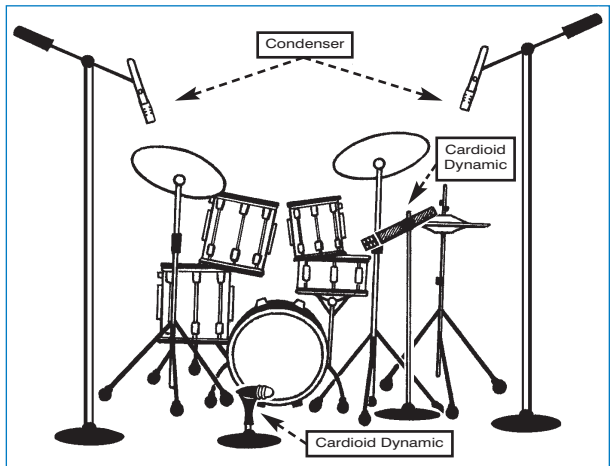

Figure 5

If you have a limited number of microphones, use the following chart:

Number of Microphones	Positioning
One	Use an "overhead"
Two	Kick drum and overhead
Three	Kick drum, snare, and overhead
Four	Kick drum, snare, and two overheads

## Audio Systems Guide for MUSIC EDUCATORS

**Piano**—For a grand or baby grand, place a condenser microphone roughly 12 inches above the middle strings, and 8 inches from the hammers. The lid should be at full stick to allow enough clearance for the microphone. For an upright, place a similar microphone just over the open top, above the treble strings (see figure 6).

**Woodwinds**—Use a dynamic microphone placed a few inches above the bell and aimed at the sound holes (see figure 7).

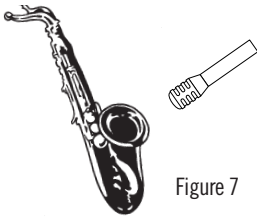

Figure 7

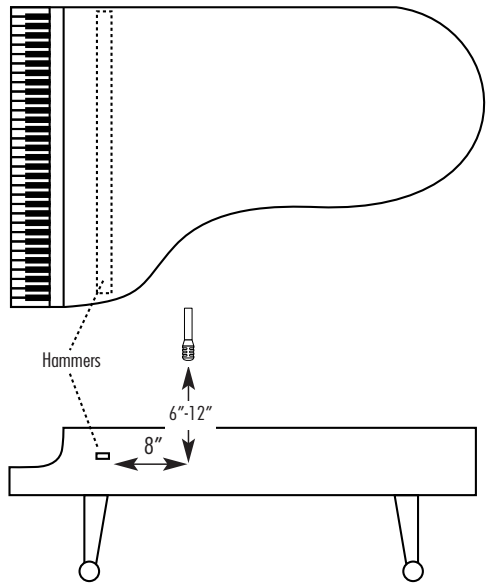

Figure 6

**Brass** – Place a dynamic microphone 1 to 2 feet in front of the bell. The closer the microphone, the brighter the sound.

### Recording devices

Two main things to consider when choosing a recording format are sound quality and ease of use. While it may be tempting to buy the same gear that the local recording studio has, keep in mind your abilities, and how much time you are willing to devote to pouring over manuals and pushing little buttons. Let's take a look at some of the more popular formats, though a few might be on the wane.

#### Flash Memory (SD Card) Recorders

These devices use small flash cards (often called SD cards) to record sound – the same flash cards commonly used for digital photography. Compatibility of these cards can be an issue, so before you opt for flash memory, consider how you will transfer the captured recordings to your computer or other mixing and file-sharing devices.

#### Hard Disc Drive Recorders

As the costs for storage plummet, the affordability of capacity (allowing for longer recording time and higher recording quality) becomes more accessible to the non-professional. While these devices are becoming increasingly portable, they are generally more for high-end recording needs.

### **Compact Disc (CD-R) Recorders**

Until recently, CD-R recorders were one of the more prevalent recording devices and easily transportable from the device to a computer. More and more, however, computers and laptops are being supplied without CD slots and files are being shared via the internet versus ‘burning’ new CDs. As above, before you opt for any device, consider how you will transfer files from the device to where you will edit and share it.

### **PC-based (Direct to Computer) Recorders**

PC-based recording, that is, recording directly to your computer or laptop is becoming the common, flexible and inexpensive way to record high quality audio. Computers are very useful for making multitrack recordings, which requires several tracks of audio recorded and later combined into a stereo mix. Unfortunately, a full discussion of multitrack recording techniques is beyond the scope of this booklet.

Interfacing a microphone with a computer is no longer a tricky proposition. A wide variety of interfaces are available that convert microphone signals to USB or Firewire, allowing you to easily connect any professional microphone to a computer. Alternatively, many microphone manufacturers, Shure included, provide microphones with USB connectors and even handy applications that can help you easily capture and edit high quality sound. In any case, if you do plan to record direct to your PC, make sure to have audio-editing software on your computer. And we strongly suggest you do not rely on the PC’s built-in microphone.

### **Smart Phone & Tablet Recorders**

Similar to PC-based recording, you can also record directly to a smart phone or your tablet device, either using the built-in microphone (less quality and control) or a plug-in microphone, which provides far higher quality and often includes an app that lets you mix and edit the sound ... as well as export into video and web-ready sound files. Again, if you do plan to record with your smartphone or tablet, make sure to have audio-editing software on the device or on your computer if you plan to transfer the files there.



Example of a smartphone and tablet-ready microphone.

### **Mixers**

Most likely, the recording device you choose will not allow you to directly connect a microphone to it. This is where the mixer comes into play. Mixers come in many varieties, a basic mixer will suffice for this application. Be sure that the mixer you choose has enough inputs to handle the number of microphones you are using. Another useful feature, common on just about all modern microphone mixers, is something called phantom power. Not nearly as mysterious as it sounds, **phantom power** is simply a voltage that travels up the microphone cable to power condenser type microphones. Dynamic microphones do not require phantom power, nor will they be harmed if they are plugged into a microphone input that has phantom power turned on. See the "Sound Reinforcement" section for a more complete discussion of mixers.

## Hooking it up

- Step 1: Position the microphones as per the previous instructions.
- Step 2: Using the XLR microphone cable, connect the microphones to the mixer inputs.
- Step 3: If you are using condenser microphones, be sure phantom power is turned on at the mixer.
- Step 4: Connect the outputs of the mixer to the inputs of the recording device with the proper cables.
- Step 5: Have the ensemble perform, and set levels accordingly (see the instructions supplied with the mixer and/or recording device).
- Step 6: Hit RECORD, and play!

## SOUND REINFORCEMENT FOR MUSIC

### *What do I need?*

### A basic sound system

A sound reinforcement system and a recording setup have two major components in common, microphones and mixers. Microphones are used to capture the sound, and the mixer is used to combine those signals together. The output of the mixer, instead of feeding a recording device, is connected to a power amplifier, which boosts the signal to "speaker" level. One or more loudspeakers are connected to the outputs of the amplifier. At this point the signal is converted from the electrical domain back to the variations in air pressure we recognize as sound, albeit at a much higher level.

Signal processors are devices, usually connected between the mixer and power amplifier, used to enhance the signal or fix problems with the sound. The most common types of processors are **equalizers**, **effects processors**, and **compressors**. An **equalizer** is basically an extremely selective set of tone controls that allow you to boost or cut specific frequencies. Typical applications for equalizers are tone shaping and feedback control (see sidebar on feedback - page 20). **Effects processors** are used to create special sound effects, such as **reverb** (sounds like a big, reverberant room) and **delay** (echo), among others. **Compressors** control varying signal levels. A loud signal that passes above the compressor's threshold is reduced (or compressed) by a given amount. A compressor can also help prevent distortion or damage to the loudspeakers. Of the processors listed above, the equalizer is the most useful in just about any sound reinforcement application.

## Microphones

Many of the same microphone rules used in recording apply equally as well for live sound reinforcement. If you skipped the recording chapter, please back up and read the section on microphones – the laws of physics don't change for sound reinforcement.

A major difference between microphone placement in live sound versus recording is proximity to the sound source. The goal in sound reinforcement is to get the microphone as close as possible to the sound source, for two reasons:

- Primarily, placing all microphones as close as possible achieves maximum sound level before feedback occurs.
- Secondly, close-miking improves isolation of the desired sound source and reduces pickup of unwanted sounds.

Other general recommendations for live sound microphone techniques include:

- Try to get the sound source (instrument, voice, or amplifier) to sound good acoustically before attempting to put a microphone on it.
- Use as few microphones as necessary. The more microphones you use, the more likely you are to have feedback problems. Using fewer microphones will allow more volume before feedback occurs.
- When multiple microphones are used, the distance between microphones should be three times the distance from each microphone to its intended sound source. This prevents comb filtering, an unpleasant, hollow sound created when two or more microphones pick up the same sound source. This technique is known as the **3-to-1 Rule** (see figure 8).

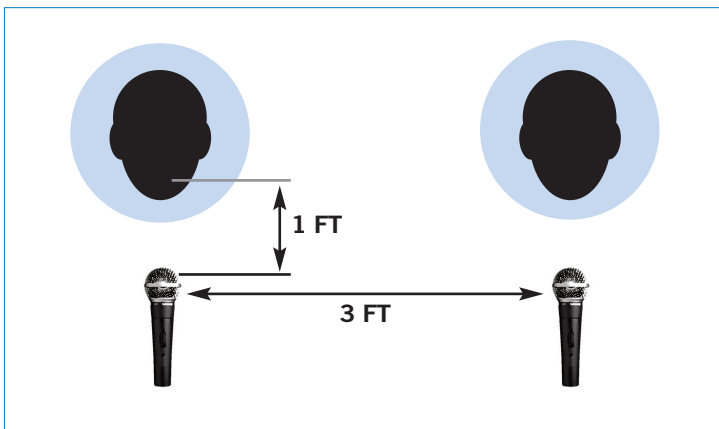

Figure 8: 3-to-1 rule

## Audio Systems Guide for MUSIC EDUCATORS

### ***Large ensembles (band, orchestra, choir)***

Large ensembles generally do not need much sound reinforcement, unless the performance area is unusually spacious. For choirs, use a technique known as area miking (see figure 2, page 7). To determine the right number of microphones, use one for every 10-15 voices. Remember not to use more microphones than absolutely necessary and follow the **3-to-1 Rule** (see page 13). As in recording, use a flat **frequency response** condenser, preferably in a cardioid-pattern. If the microphones will be suspended from the ceiling, make certain they are aimed towards the singers' mouths, not at tops of their heads. Handheld, dynamic microphones are designed for up-close use only, and are not appropriate for choir-miking under any circumstance.

Similar techniques apply to orchestras and concert bands. Depending on the size of the ensemble, use at least one microphone per section. Remember to keep the microphones as close in as possible and as far from the loudspeakers as possible. For soloists or lead instruments, consider using a microphone attached directly to the instrument. Miniature condenser microphones can be attached or clipped onto the bells of brass and woodwind instruments or the chin rest of string instruments.

### ***Recommended Equipment***

- One condenser microphone per section; cardioid
- Soloist microphones – (horns, stand-mounted or horns or strings, clipped-on); cardioid
- Choir microphones – (permanent install, hung from ceiling or stand-mounted); cardioid
- Microphone stands
- An assortment of XLR microphone cables in varying lengths
- A mixer with enough input channels
- Power amplifier
- Loudspeakers
- Interconnect cables
- Signal processors (if desired)

### ***Small ensembles (jazz combos, string quartet, vocal jazz groups)***

For smaller groups, close-miking becomes essential for reducing *leakage* between the instruments. Let's examine each instrument type individually.

**Lead vocal** - Use a handheld, directional microphone. The microphone should be touching the lips or just a few inches away. The same technique applies to background vocalists (see figure 3, page 9).

**Electric Guitar Amplifier** – Use a cardioid dynamic microphone roughly 1-4 inches from the loudspeaker, pointed toward the center of the speaker cone (see figure 4, page 9).

**Drums** – Jazz Band – Generally, three microphones are sufficient to achieve an authentic jazz drum sound. Place one directional dynamic microphone in front of the kick drum, and use a pair of decent directional condenser microphones above the kit for cymbals, toms, and snare drum.

**Drums** (see figure 9) – Rock Band – To get a "big" rock sound, try to place a microphone on every drum, with the following guidelines:

**Snare drum** - Use a dynamic microphone on a short boom stand. Aim the microphone at the top head, just above the top edge of the drum.

**Kick (bass) drum** - Use a front drum head that has a hole in it, or remove the front head altogether. Mount a microphone on a short boom and position it inside the drum a few inches from the beater head, on axis with the beater. Use a wood beater to get more "attack", or stuff the drum with a blanket or pillows to reduce boominess.

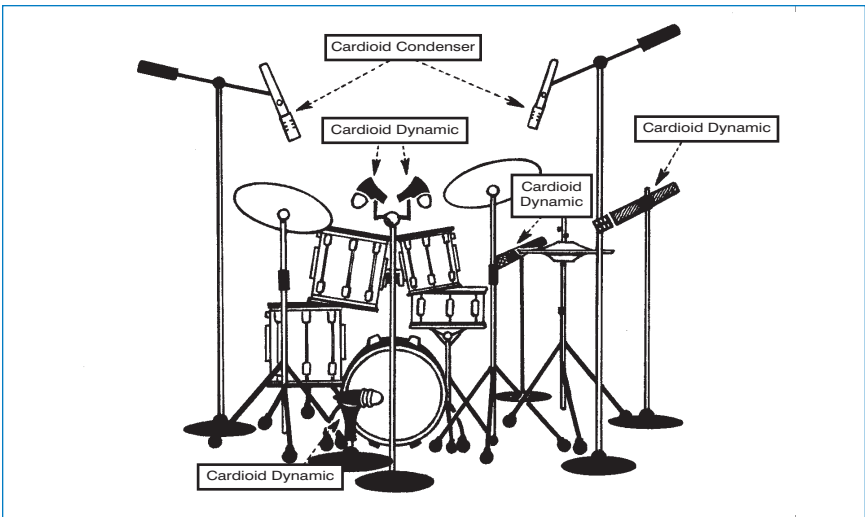

Figure 9

## Audio Systems Guide for MUSIC EDUCATORS

**Tom-toms** – Use one microphone for every two toms. Position them close to the heads, in a similar method as used for the snare drum. If enough microphones are available put one on every tom-tom.

**Cymbals** – Place a condenser microphone above the hi-hats, pointed down and slightly away from the drummer. Or, angle the snare mic slightly towards the hi-hats. To pick up the rest of cymbals, place another condenser near the ride cymbal, a foot or two above.

**Piano** – Open the lid and aim a condenser microphone just over the top, above the treble strings (see figure 10).

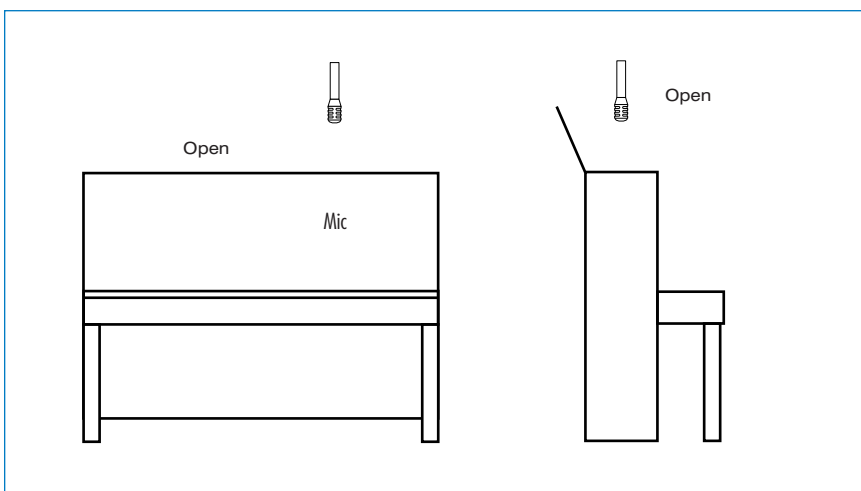

Figure 10

**Grand piano** – Use two flat-response condenser microphones, one positioned 12 inches above the treble strings and the other above the lower strings. Both mics should be about 8 inches from the hammers.

**Upright bass** – For the most natural sound, place a condenser about 6 inches in front of the bass, just above the bridge.

**String quartet:** For violins and violas, use a miniature condenser microphone clipped to the instrument. The best place to attach a microphone without altering the sound of the instrument is the chin rest. For cellos, use a stand-mounted condenser microphone aimed at the bridge, about a foot away.



**Saxophone** (see figure 11) – Again, a miniature condenser microphone clipped to the instrument and aimed into the bell yields good, up-front sound quality with great isolation. Alternatively, a dynamic microphone on a stand provides similar results, but restricts movement.



Figure 11

**Brass (Trumpets, trombone, tuba)** – Similar to the saxophone, clip a condenser to the bell of the instrument. If the sound seems excessively bright, especially the trumpet, try slightly off-axis to get a more mellow tone.

### **Recommended Equipment**

- Vocal microphone; cardioid
- Guitar amplifier microphone; cardioid
- Drum microphones; cardioid
- Piano microphone; cardioid
- Woodwind microphones; cardioid
- Brass microphones; cardioid
- Stringed instrument microphones; cardioid
- Microphone stands
- An assortment of XLR microphone cables in varying lengths
- A mixer with enough input channels
- Power amplifier
- Loudspeakers
- Interconnect cables
- Signal processors (if desired)



Example of a  
Dynamic Vocal  
Microphone

## **Mixers, Amplifiers and Loudspeakers**

As in recording, mixers are used to combine microphone signals together. Mixers designed for sound reinforcement of musical instruments usually feature a set of extra controls for each microphone beyond just a volume control. These typically include a **gain**, or **"trim" control**, an **EQ** section, a set of **auxiliary** send volume controls, a **bus** section, a **pan** control, and a **fader** for volume control (see figure 12, page 18).

The **gain control** boosts the signal from microphone level up to line level. The next stage is the **EQ**, used for tone shaping. A typical mixer will have knobs to boost or cut the highs and lows. Also common is a "sweepable" midrange, which utilizes two controls. One knob selects the frequency, and the other one boosts or cuts that frequency.

# MUSIC EDUCATORS

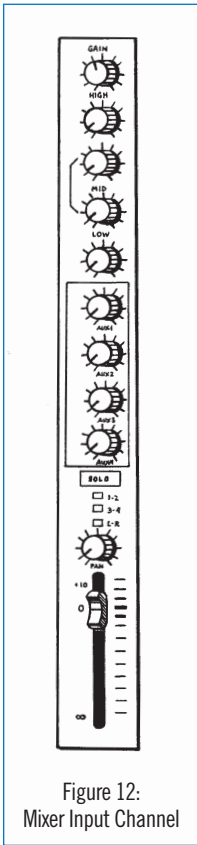

Figure 12:  
Mixer Input Channel

**Auxiliary sends** are additional outputs from the mixer that can be used to route the microphone signal to other devices without affecting the main output of the mixer. Common applications for auxiliary sends include stage monitors or effects processors. The **bus** section is used to assign the microphone signal to the main outputs of the mixer. The **pan** control typically serves two functions, either working with the bus section to choose which output the signal is routed to, or to adjust the left-to-right balance if you are using a stereo sound system. At the bottom of the channel strip is the **fader**, which gives you precise control of the volume of each microphone that is assigned to the master outputs of the mixer.

Amplifiers and loudspeakers work together to reproduce the combined microphone signals from the mixer at a much higher level. A typical power amplifier has two inputs (left and right) and two outputs to connect to loudspeakers. Note that amplifier outputs are designed for loudspeakers only! The signal at this point is much too high to connect to any device besides a loudspeaker. Most amplifiers also have input sensitivity controls as well.

Loudspeakers (see figure 13) come in many shapes and sizes, choosing the right one depends largely on the individual application. Some things to consider: the size of the auditorium, portability requirements, and budget. Most sound reinforcement loudspeakers are multi-way devices, which means each speaker cabinet includes two (or more) individual loudspeakers, each optimized to reproduce a specific frequency range. Two-way boxes with a

woofer for low frequencies and a horn for highs are the most common variety. This type of loudspeaker is appropriate for applications involving voice reproduction and most musical instruments that do not require a good deal of low-end response. Subwoofers can complement the two-way boxes for rock bands or music with a considerable amount of low frequency content. Large touring sound systems occasionally employ up to a five-way system.

For ease of setup and portability, these devices are occasionally combined into one unit, either a powered mixer (mixer/amplifier) or powered loudspeaker (amplifier/loudspeaker).

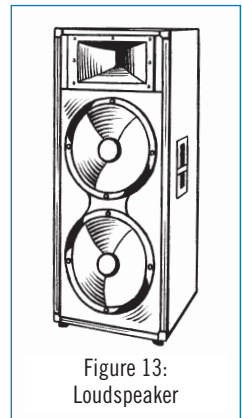

Figure 13:  
Loudspeaker

## Signal Processors

A signal processor enhances the audio signal, or can assist in correcting imperfections in the sound system. While not usually essential to the operation of a sound system, they offer some significant advantages. Signal processing equipment includes equalizers, special effects processors, and dynamic processors.

Equalizers come in two basic varieties: graphic and parametric. The graphic equalizer (see figure 14) is the most common type. The controls on a graphic equalizer consist of a row of faders that are used to cut or boost specific frequencies. The more faders there are, the more precise the level of control. Each fader represents a "band"; common graphic equalizers are 5-band, 10-band, 15-band, and 31-band. Graphic equalizers give the user visual "feedback" (no pun intended) by graphically representing which frequencies have been cut or boosted. While easy to use, graphic equalizers only allow alteration of the frequencies shown on the front panel. For example, a 31-band equalizer allows you to cut at 400 **Hz (Hertz)** and 500 Hz, but not anywhere in between. A cut at 450 Hz could be simulated by reducing both 400 and 500 Hz, but this results in cutting more frequencies than is necessary. A parametric equalizer, on the other hand, offers more precise control. Fully parametric equalizers consist of three controls; frequency, boost/cut, and bandwidth. The frequency control permits the user to select a specific frequency, the boost/cut control selects how much that frequency is raised or lowered, and the bandwidth control selects how many adjacent frequencies are affected by the adjustment.

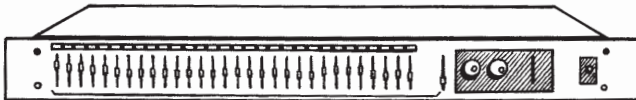

Figure 14: Graphic Equalizer

Equalizers are often employed in an attempt to control feedback. While not the ultimate solution (see sidebar on feedback, page 20), they can be a useful tool in this application. To begin, turn on all microphones, and raise their individual levels to the point where they will most likely be used during the performance. Slowly bring up the master output level of the mixer until feedback occurs. Now go to the equalizer and pull down the offending frequency roughly **3dB (decibel)**. If the feedback is a "hoot" or "howl" try cutting in the 250 to 500 Hz range. A "singing" tone may be around 1 kHz. "Whistles" and "screeches" tend to occur above 2 kHz. Very rarely does feedback occur below 80 Hz or above 8 kHz. It takes practice to develop an ear for equalizing a sound system, so be patient. After locating the first feedback frequency, begin turning up the system again until the next frequency begins ringing. Repeat the above steps until the desired level is reached, but do not over equalize. Keep in mind the equalizers can only provide a maximum level increase of 3 to 9 dB. Parametric equalizers, though more confusing to the novice user, allow for more precise control of feedback frequencies.

## Audio Systems Guide for MUSIC EDUCATORS

Automatic feedback reducers will accomplish the same results as above. They find and cut the frequencies that are feeding back automatically. The same precautions listed above apply to feedback reducers as well as equalizers. Automatic feedback reducers are very helpful in wireless microphone applications. Remember that microphone placement is crucial to eliminating feedback, and the temptation to wander away from the ideal microphone position when using a wireless is great. If the performer gets too close to a loudspeaker, feedback will result; a good feedback reducer will be able to catch and eliminate the feedback faster than a human operator.

### ***Feedback***

One of the most commonly asked questions in professional audio is "What microphone can I use that doesn't cause feedback?" The answer to the question is, of course, that no such microphone exists. Feedback results from a combination of many factors, including loudspeaker placement, microphone placement, the frequency response of both devices, and room acoustics.

#### **What is feedback?**

Feedback is characterized by a sustained, ringing tone, which can vary from a low rumble to a piercing screech. Echoes and reverberation caused by room acoustics, as well as ground buzz and other extraneous noises, are not the same thing as feedback, and cannot be cured in the same manner.

#### **What causes feedback?**

Feedback occurs whenever the sound entering a microphone is reproduced by a loudspeaker, picked up by the microphone, and re-amplified again and again. The familiar howl of feedback is an oscillation that is triggered by sound entering the microphone. The easiest way to create feedback is to point a microphone directly into a loudspeaker. (We don't recommend you try this!) Placing the microphone too close to the loudspeaker, too far from the sound source, or simply turning the microphone up too loud exacerbates feedback problems. Other contributing factors are too many open microphones, poor room acoustics, and uneven frequency response in either the microphones or loudspeakers.

**What can I do about feedback?**

The single easiest way to reduce feedback is to move the microphone closer to the desired sound source. Additionally, using a directional microphone (*cardioid*, *supercardioid*, etc.) will typically increase the amount of gain before feedback. In live sound reinforcement, reducing the number of open microphones with an *automatic mixer* will also improve the situation. Try to keep microphones and loudspeakers as far away from each other as possible. Lastly, acoustically treat the room to eliminate hard, reflective surfaces such as glass, marble, and wood.

When all of the above solutions have been exhausted, the next step is to look towards equalizers and automatic feedback reducers.

Compressors, as mentioned above, are used to control varying sound levels. When a singer is performing, certain notes or phrases tend to be louder than others. Typically, that singer's volume is set to the maximum possible level without causing distortion further downstream in the sound system. In a loud environment, quieter passages will get lost unless someone "rides" the vocal fader to boost the singer during these quiet passages. The volume then needs to be reduced to prevent distortion when the singer gets loud again. A compressor allows the volume to be left at the "boosted" level by reducing the peaks (loud parts) by a preset amount so they don't cause distortion. An unfortunate myth that arose from this practice promotes the idea that the compressor actually makes quiet sounds louder. Two controls common to most compressors are *threshold* and *ratio*. The *threshold* determines at what point the compressor function activates, and *ratio* controls how much the signal is compressed. A lower threshold causes the compressor to activate on quieter sounds, while a higher threshold requires louder sound to activate. Similarly, a lower ratio control reduces the level by a small amount (e.g. a ratio of 2:1 results in a level half of what it would normally be.) A higher ratio (such as 10:1) would reduce the signal to a much greater degree.

A specialized form of compressor, called a limiter, uses a very high ratio (often  $\infty$ :1) that prevents any signal from surpassing the level set by the threshold. Limiters are primarily used as overall system protection at the output of the mixer, while compressors are typically employed on an individual channel basis.

Finally, special effects processors allow the user to add ambience (reverb) or create unique sounds (chorus, flange, delay).

## Audio Systems Guide for MUSIC EDUCATORS

### Hooking it up

- Step 1: Position the microphones as per the previous instructions.
- Step 2: Using the XLR microphone cables, connect the microphones to the mixer inputs (see figure 15).
- Step 3: If you are using condenser microphones, be sure phantom power is turned on at the mixer.
- Step 4: Connect the outputs of the mixer to the inputs of the signal processors (if any) and then to the inputs of the power amplifiers.
- Step 5: Connect the speaker outputs of the amplifiers to the inputs of the loudspeakers.
- Step 6: **IMPORTANT!** Always turn the mixer and any signal processors on first. Then turn the amplifiers on. This prevents possible damage to the loudspeakers. When powering down the system, always turn the amplifiers off first.
- Step 7: Begin setting levels by placing all the input and master faders at "0." Check each microphone one at a time by bringing the gain control up (while the musician plays) until the output level meter reads "0", then back down the gain slightly. Repeat this step for each microphone. **NOTE:** At this point the amplifier inputs should be all the way down.
- Step 8: While the ensemble plays, bring up the input level controls on the amplifier until the sound reaches the desired level.
- Step 9: Adjust the faders to achieve the proper blend of the instruments. Avoid pulling any faders down to the bottom part of their travel. If a particular channel needs a drastic reduction in level, reduce that channel's gain control instead of the fader.

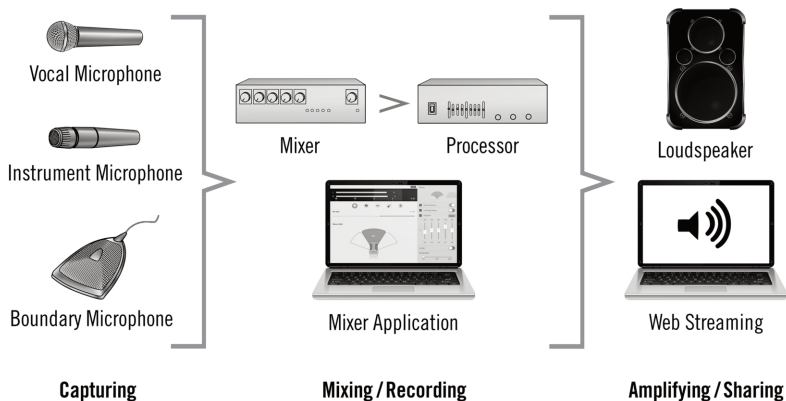

Figure 15: Common sound chain

## **SOUND REINFORCEMENT FOR THEATER**

### **The Realities of Theater Sound**

#### *Microphones for everybody!*

Most theaters that operate on a limited budget try to use as few microphones as possible. Common techniques include hanging a few microphones overhead, and maybe a few **boundary (or surface mount) microphones** at the front of the stage. Many inherent problems exist with these techniques, including, but not limited to:

- Reduced gain before feedback due to too many open microphones too far away from the actors.
- Comb filtering (that thin, hollow sound) resulting from multiple microphones picking up the same actor.
- Increased pickup of stage vibration noise, reverberation, and other unwanted sounds.
- Varying sound levels as actors move in and out of the pick-up areas of different microphones.

How do professional theaters deal with these issues? Easy - they don't. Every performer on stage gets a wireless microphone. Most Broadway productions use over a hundred thousand dollars worth of wireless microphones for a single show. A basic rule of microphone technique for any application is to get the microphone as close as possible to the desired sound source. Therefore, even though you can't always see it, each actor has a small **lavalier microphone** clipped, taped, glued, or sewn to some part of the face, hair, or costume. Having every actor "close-miked" eliminates all of the above problems encountered with distant miking. The distance between the microphone and the actor's mouth remains constant, thus providing a constant output level. High sound level shows go a step further, using **headworn microphones** to get the microphone even closer to the sound source.

#### *The Overhead Dilemma*

Okay, so your budget doesn't quite get up to Broadway standards. Using a few **overhead microphones** for smaller speaking parts can be an acceptable alternative, but be realistic about what to expect. Consider the following example:

Two actors on stage, one is wearing a lavalier microphone six inches from his mouth, the other is standing six feet from the nearest overhead microphone. The actor wearing the lavalier will be four times louder than the other actor will! Turning the microphones up louder is not always an option, either. For any given sound system, the farther the microphones are from the sound source, and the closer they are to the loudspeakers, the less you can turn them up before feedback occurs. Multiple open microphones will further increase the

## Audio Systems Guide for MUSIC EDUCATORS

chances for feedback. In addition, distant microphones will pick up more ambient sound, making the actors sound farther away, when compared to close-miked actors. If you choose to use overhead microphones, pay close attention to where the actors are standing when they speak. If the actors are always as close to the microphones as possible, sound quality will improve. Turning down unused microphones will also help.

For downstage areas, or runways where it is not practical to hang an overhead microphone, boundary microphones are often used. These small, flat microphones are usually placed at the edge of stage, where they will be out of the actors way. Boundary microphones are not magic; they are subject to the same limitations as overhead microphones, with the additional issue of stage vibration pick-up.

Overhead and boundary microphones that you may see in a Broadway production are not necessarily used for sound reinforcement; many times they are used for hearing assist, backstage cues, or recording.

One final note on microphones: shotgun microphones are never used for sound reinforcement! The **shotgun microphone** was designed for film and video production work, where the microphone signals are going straight to tape. It does not "focus" on the sound coming from the stage, nor does it filter out unwanted sounds. A shotgun placed at the back of the hall will pick up everything that happens between the microphone and the stage.

### **Acoustics**

Another issue that can plague amateur theater is poor acoustics. The typical "cafe-gymna-torium" that is used for many school and church theatrical productions is, acoustically speaking, the worst possible place for sound reinforcement. These rooms tend to be extremely "echo-y", which limits intelligibility (the ability to understand what is being said) and decreases gain before feedback (how loud you can turn up the sound system). Professional productions are done in quiet, non-reflective, controlled environments that are optimized for theater sound. Many theaters also employ a distributed sound system, which uses many speakers placed throughout the venue that are divided into "zones". Each zone is fed a varying amount of signal, depending on how far they are from the stage. Loudspeakers nearest the stage get very little, if any, signal, while those at the back get proportionally more. This also allows the overall volume level to be lower, which improves intelligibility in a poor acoustic environment.

### **Know your performers!**

Lastly, remember to keep in mind the skill level of the performers involved. Professional actors and singers know how to project their voice, which creates more signal level at the microphone. Children, especially shy ones, do not make much sound, which further necessitates close-miking techniques. As mentioned above, turning distant microphones up louder will most likely result in feedback. Remember, if you can't hear what the actors are saying from six feet away, the microphone certainly can't either!



If the above examples seem to paint a grim picture, don't despair. Placing the microphones as close as possible to the actors mouths will always result in improved sound quality. Just be aware that overhead microphones, used carefully, can increase intelligibility for smaller speaking roles. What they cannot do, however, is create a Broadway-like experience. Wireless microphones and carefully controlled, expensive sound systems operated by top-flight sound technicians are the science behind the illusion in professional theater.

## Lavalier Microphone Techniques for Theater

The object of most theatrical microphone techniques is to make the mics as inconspicuous as possible and provide the actors with freedom of movement, while still providing a high level of sound quality. The obvious choice is wireless lavalier microphones, which are becoming increasingly popular. Today it is common to find Broadway productions that incorporate twenty to thirty wireless microphone systems on a nightly basis. This section presents a few tips and techniques to get the best results from lavalier microphones.

**Place the microphone near the top of the chest, above the ear, or in the hair line** (see figure 16). A common mistake is to place the mic near the throat, but this will lead to an unnatural sound due to a "shadow" created by the chin that will block high frequencies from reaching the microphone.

**Use an omni-directional mic if you have to position it above the ear or in the hair line.** A side-effect of directional mics (cardioid, supercardioid, etc.) is off-axis coloration, an uneven pickup of the sound that results when addressing a directional microphone from the side or rear (off-axis). A mic placed on the head will, of course, always be off-axis unless it is right in front of the mouth. *Omnidirectional* mics will sound more natural when placed away from the mouth.

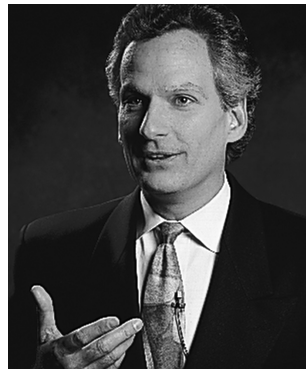

Figure 16:  
Lavalier Microphone Placement

**Consult the wig master on securing mics near the hair line.** Mic cables can be secured in the hair in several ways, including wig clips, comb clips, sewing them into barrettes, bobby pins, and elastic headbands. Also, the mic can be mounted on the temple of eyeglasses.

**Never use "Gaffer" tape to secure a cable to the skin.** The adhesive found on this tape can cause skin irritation, as well as just being too sticky. Suggested alternatives include surgical tape, spirit gum, medical adhesive, and clear bandage tape.

## Audio Systems Guide for MUSIC EDUCATORS

**Be sure to provide strain-relief for the mic cable behind the neck.** The point where the neck bends needs to be the most secure. If no strain relief is present, a sharp neck movement could tug the mic out of place. Again, surgical tape and elastic headbands are good choices for securing the mic cable to the neck.

**Be careful not to get make-up in the opening of the microphone element.** Any make-up that gets into the mic element will alter the frequency response, and could destroy the element altogether.

**If the mic cable is run inside clothing, tape the mic and cable to the fabric to prevent contact noise.** Contact noise is caused by clothing rubbing against the mic capsule or cable. A little tape and some careful positioning can help eliminate this problem. Also, tie a simple knot in the mic cable near the microphone. This will also assist in blocking cable noise from getting into the microphone.

**Consult the wardrobe master to help prevent clothing noise.** Clothing noise is caused by garments rubbing against each other. There is no practical way to shield the mic from this noise, so it is a good idea to plan ahead with your wardrobe people. Generally, synthetic materials make more noise than natural fabrics, such as cotton. Also, ask wardrobe to tape or sew together multiple layers of clothing to prevent rustling.

**Don't be afraid to use equalization.** Judicial use of high frequency boost can help brighten a mic covered by clothing or positioned in the hair line. Low frequency cut reduces cable noise, breath pops, and wind noise.

**Keep spare mics on hand at all times.** Many professional theater companies consider lavalier microphones a disposable item. Condenser microphones especially can be easily destroyed in such an abusive environment. Sweat, make-up, and constant tugging on cables and connectors can quickly wear out even the highest-quality microphone. Try to inspect your mics on a regular basis by plugging them in and listening for any odd noises and crackling, or degradation of frequency response. Wiggle the cables and connectors to check for loose connections.

**Take the headworn approach.** More and more, actors in Broadway musicals use headworn microphones. The mic placement is always consistent, and right in front of the mouth for best sound quality and better gain before feedback. Headworn mics also give you that "hip, 21st century" look!

## **SUMMARY**

The techniques and concepts introduced here only scratch the surface of what can be accomplished with some basic audio equipment. Feel free to experiment and develop your own techniques, just remember a few key points:

1. Use only as many microphones as necessary.
2. Keep the microphones as close as possible to the sound source.
3. When powering up the sound system, turn amplifiers on LAST and off FIRST.
4. Overhead and boundary microphones will never sound like a lavalier.
5. If it sounds good, it is good!

For more information visit the Shure Pro Audio Web site, [www.shure.com/proaudio](http://www.shure.com/proaudio) or read the following publications available from Shure:

### **Microphone Techniques for Music: Sound Reinforcement,**

Rick Waller, John Boudreau, and Tim Vear.

This book contains two sections, one that details microphone characteristics, acoustics, and musical instrument characteristics, and a second that details microphone placement for a variety of instruments. Also includes a section on stereo miking and a Shure microphone selection guide.

### **Microphone Techniques for Music: Studio Recording,**

John Boudreau, Rick Frank, Tim Vear, and Rick Waller.

Similar in scope to the Sound Reinforcement guide, but with an emphasis on recording studio applications.

Recommended Shure Microphone Models

<b>Recording</b>		
<b>Usage</b>	<b>Model(s)</b>	<b>Pattern(s)</b>
Vocals	Beta 58A SM58, PGA58	Supercardioid Both cardioid
Guitar	SM57, PGA57	Both cardioid
Drums, Snare	SM57	Cardioid
-Kick (bass)	Beta 52A PGA52	Supercardioid Cardioid
-Toms/Cymbals	PGA81, SM81	Both cardioid
Piano	PGA81, SM81, KSM27	All cardioid
Woodwinds	SM57, PGA57	Both cardioid
Brass	SM57, PGA57	Both cardioid
<b>Sound Reinforcement for Music</b>		
<b>Usage</b>	<b>Model(s)</b>	<b>Pattern(s)</b>
Condenser	PGA81, SM81	All cardioid
Choir	MX202, PGA81	OC or S, Cardioid
Lead vocals	Beta 58A SM58, PGA58	Supercardioid Both cardioid
Electric Guitar	SM57, PGA57	Both cardioid
Drums, Snare	SM57	Cardioid
-Kick (bass)	Beta 52A PGA52	Supercardioid Cardioid
-Toms, Cymbals	SM57, PGA56	Both cardioid
Piano	PGA81, SM81, KSM27	All cardioid
Saxophone	Beta 98H/C, SM57 (on stand)	Both cardioid
Brass	Beta 98H/C, SM57 (on stand)	Both cardioid
Strings	SM57, Beta 98H/C	Both cardioid
<b>Sound Reinforcement for Theater</b>		
<b>Usage</b>	<b>Model(s)</b>	<b>Pattern(s)</b>
Overhead	MX202	OC or S
Boundary	MX391	OC or S
Lavalier	WL93, WL50, WL51	S, O, C
Headworn	WH30, WBH53	Cardioid, O

Key: O = omnidirectional, C = cardioid, S = supercardioid

**Shure Microphone Product Categories:**

**PG ALTA** – Affordable, application specific microphones ideal for everyday use and practice. 💰

**SM Line** – Performance tested, industry standard microphones for more critical applications. 💰 💰

**Beta Line** – Premier live performance microphones. Sensitive to fine sound details in all demanding environments. 💰 💰 💰

### Appendix: Selected Reading

#### **Live Sound for Musicians,**

Rudy Trubitt, ISBN: 0-7935-6852-8

A math-free, step-by-step guide to getting a basic sound system up and running. This book contains a plethora of troubleshooting tips and set-up hints. Everything is explained in plain English with as little technical mumbo-jumbo as possible. Especially recommended for do-it-yourself musicians and volunteer sound people at churches.

#### **The Home Studio Guide to Microphones,**

Loren Alldrin, ISBN: 0-918371-22-8

For anyone who has, or wants to have, a home recording studio. This book contains a wealth of detailed technical information on microphones, as well as microphone techniques for a variety of instruments, and a microphone selection guide that covers nearly every microphone you might consider for your home studio.

#### **Sound Design in the Theatre,**

John L. Bracewell, ISBN: 0-13-825167-3

This easy to read volume includes the usual descriptions of sound reinforcement components, with additional sections focusing on playback systems (both analog and digital), synthesis and samplers, MIDI, and the creative aspects of theater mixing. The basic electronics explanations are among the most understandable of any of these books. The book concludes with a detailed account of system design and implementation for an actual production.

## **BIOGRAPHY: Gino Sigismondi**

Gino is a Shure Associate since 1997 and has been active in the music and audio industry for over twenty years. In addition to his work as a live sound and recording engineer, Gino's experience also includes performing and composing. Gino earned his BS degree in Music Business from Elmhurst College, where he was a member of the Jazz Band, as both guitar player and sound technician. Currently leading the Systems Support group at Shure, Gino and his team provide technical support for high-end Shure wireless and conferencing products that rely on software, firmware, and networking. Additionally, he conducts training seminars for Shure customers, dealers, distribution centers, and internal staff.

**3-to-1 Rule** – When using multiple microphones, the distance between microphones should be at least 3 times the distance from each microphone to its intended sound source.

**Automatic Mixer** – A specialized mixer that turns off unused microphone channels without any user intervention, and turns on microphone channels as needed.

**Boundary/Surface Microphone** – A microphone designed to be mounted on an acoustically reflective surface.

**Cardioid Microphone** – A unidirectional microphone with moderately wide front pickup (131 degrees). Angle of best rejection is 180 degrees from the front of the microphone, that is, directly at the rear.

**Close Pickup** – Microphone placement within 2 feet of a sound source.

**Compressor** – A device that controls varying signal levels.

**Condenser Microphone** – A microphone that generates an electrical signal when waves vary the spacing between two charged surfaces: the diaphragm and the backplate.

**Decibel (dB)** – A number used to express relative output sensitivity. It is a logarithmic ratio.

**Delay (echo)** – Reflection of sound that is delayed long enough to be heard as a distinct repetition of the original sound.

**Dynamic Microphone** – A microphone that generates an electrical signal when sound waves cause a conductor to vibrate in a magnetic field. In a moving-coil microphone, the conductor is a coil of wire attached to the diaphragm.

**EQ** – Equalization or tone control to shape frequency response in some desired way.

**Feedback** – In a PA system consisting of a microphone, amplifier, and loudspeaker, feedback is the ringing or howling sound caused by amplified sound from the loudspeaker entering the microphone and being re-amplified.

**Flat Response** – A frequency response that is uniform and equal at all frequencies.

**Frequency** – The rate of repetition of a cyclic phenomenon such as a sound wave. Usually measured in Hertz (Hz).

**Frequency Response** – A graph showing how a microphone responds to various sound frequencies. It is a plot of electrical output (in decibels) vs. frequency (in Hertz).

**Gain** – Amplification of sound level or voltage.

**Gain-Before-Feedback** – The amount of gain that can be achieved in a sound system before feedback or ringing occurs.

**Headworn Microphone** – A microphone designed to be worn on the head.

**Hertz (Hz)** – A unit of measurement that represents cycles-per-second. The musical note "A" above middle "C" is equivalent to 440 Hz.

### Glossary

**Impedance** – In an electrical circuit, opposition to current flow of alternating current, measured in ohms. A high impedance microphone has an impedance of 10,000 ohms or more. A low impedance microphone has an impedance of 50 to 600 ohms.

**Lavalier Microphone** – A small microphone designed for hands-free usage. Usually clipped to the clothing.

**Leakage** – Pickup of an instrument by a microphone intended to pick up another instrument.

**Omnidirectional Microphone** – A microphone that picks up sound equally well from all directions.

**Overhead Microphone** – Microphones that are typically hung from the ceiling. Common applications are choir and theater miking.

**PA** – Public Address. Usually refers to a sound reinforcement system.

**Phantom Power** – A method of providing power to the electronics of a condenser microphone through the microphone cable.

**Reverberation** – The reflection of a sound a sufficient number of times that it becomes non-directional and persists for some time after the source has stopped. The amount of reverberation depends of the relative amount of sound reflection and absorption in the room.

**Sensitivity** – The electrical output that a microphone produces for a given sound pressure level.

**Shaped Response** – A frequency response that exhibits significant variation from flat within its range. It is usually designed to enhance the sound for a particular application.

**Shotgun Microphone** – An extremely directional microphone, commonly used in broadcast and film production applications.

**Sound Reinforcement** – Amplification of live sound sources.

**Stereo** – Two channels of audio, left and right, which can be used to simulate realistic listening environments.

**Supercardioid Microphone** – A unidirectional microphone with a tighter front pickup angle (115 degrees) than a cardioid, but with some rear pickup. Angle of best rejection is 126 degrees from the front of the microphone, that is, 54 degrees from the rear.

**Unidirectional Microphone** – A microphone that is most sensitive to sound coming from a single direction – in front of the microphone. Cardioid and supercardioid microphones are unidirectional.

## Additional Shure Audio Institute Publications Available:

Printed or electronic versions of the following guides are available free of charge. To obtain your complimentary copies, call one of the phone numbers listed below or visit [www.shure.com](http://www.shure.com).

- Microphone Techniques for Recording
- Microphone Techniques for Live Sound Reinforcement
- Selection and Operation of Audio Signal Processors
- Selection and Operation of Personal Monitor Systems
- Selection and Operation of Wireless Microphone Systems
- Audio Systems Guide for Video and Film Production
- Audio Systems Guide for Houses of Worship
- Audio Systems Guide for Meetings and Conferences

## Application and Product Videos:

The Official Shure Incorporated YouTube channel can be found at [www.youtube.com/user/shureinc](http://www.youtube.com/user/shureinc).

The Shure YouTube channel includes many *how to* videos, product descriptions and features, artist and engineer interviews, as well as other valuable content to help microphone users and audio professionals stay on top of advancements and get the most out of their audio equipment.



## Our Dedication to Quality Products

Shure offers a complete line of microphones and wireless microphone systems for everyone from first-time users to professionals in the music industry—for nearly every possible application.

For over nine decades, the Shure name has been synonymous with quality audio. All Shure products are designed to provide consistent, high-quality performance under the most extreme real-life operating conditions.

**SHURE**<sup>®</sup>  
LEGENDARY  
PERFORMANCE™

### United States, Canada, Latin America, Caribbean:

Shure Incorporated, 5800 West Touhy Ave, Niles, IL 60714-4608 USA  
Phone: +1 847-600-2000 Fax: +1 847-600-1212 (USA) Fax: +1 847-600-6446

### Europe, Middle East, Africa:

Shure Europe GmbH, Phone: +49-7262-92490 Fax: +49-7262-9249114

### Asia, Pacific:

Shure Asia Limited, Phone: +852-2893-4290 Fax: +852-2893-4055